



# **“DUTCH LEVEL” WATER LEVEL SETUP & OPERAT- ING PROCEDURES**



## **WARNING**

Unsafe use of this equipment could result in serious injury or death. This manual contains important instructions for the safe operation and recommended maintenance of your directional drill. All who operate the directional drill must carefully read and understand this manual before starting the machine. Keep this manual available both as a reminder for your experienced operator and as a training aid for your new staff.

Replacement manuals are available by calling American Augers.



**Revision Record**

---



**Revision to Manual**

Revision Number	Description of Change	Date
00	Reformatted August 2008, Revision 00	8/31/2008



Revision to Manual, Continued

Revision Number	Description of Change	Date

# Dutch Level Operators Manual

## How it Works

The level operates in the same way as the sight tube on a boiler. The small tube on the outside of the tank indicates the level of the water on the inside of the tank as long as the indicator tube is connected to the same pressure as the inside tank. In the case of the "Dutch Level", both ends of the system are vented to air pressure. A pit mounted control and indicator board is located at the some convenient point near the operator. A hose connects the bottom of the indicator tube to a water pipe running along the top centerline of the casing. Water is used to fill the system. The level of the water in the pit indicator will then show the level of the "valve" on the end of the casing as it is pushed into the ground.

A simple "toppin off" procedure is used before each reading to assure that the system is full and reading properly.

The following diagrams show how an incorrect reading could be obtained.

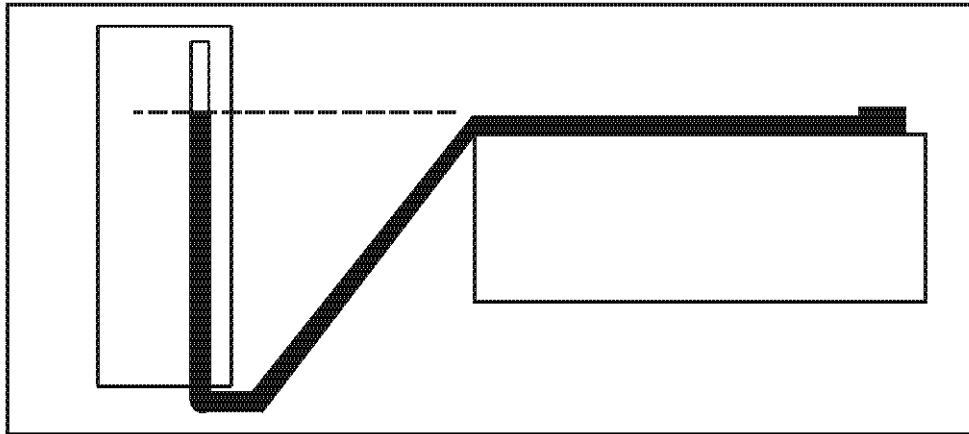

Figure 1: System full of water and indicating CORRECT level of head.

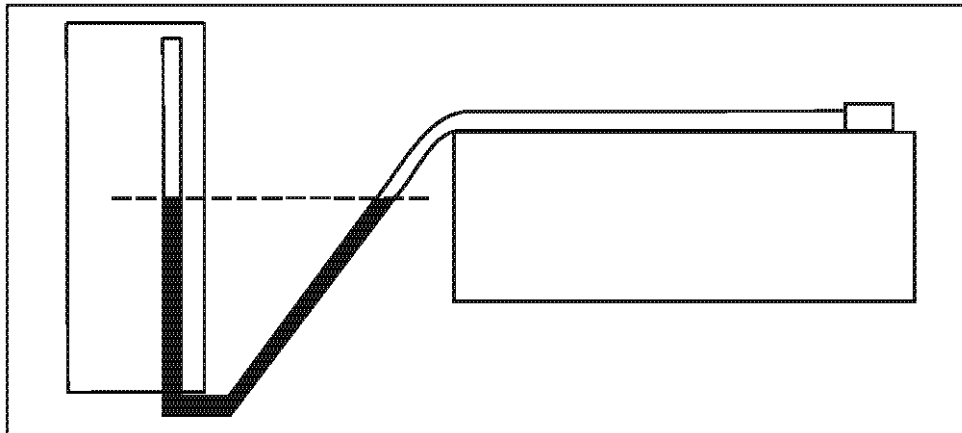

Figure 2: System partially full and indication INCORRECT level of head.



Carefull attention to the following instructions and checking the instrument before readings will help assure good results.

### Attaching the Casing Head Valve

Locate the "valve" (already attached to the first section of water pipe) on the top of the first, or lead section of pipe, and about 6 to 8 inches back from the front. Drill or burn a 1/2 inch hole in the pipe to vent excess water from the head into the pipe, and SECURELY weld the head over the hole. You will only get one shot at this operation, so do it right. If the sensing head comes off during the bore, no further use can be made of the level during that job.

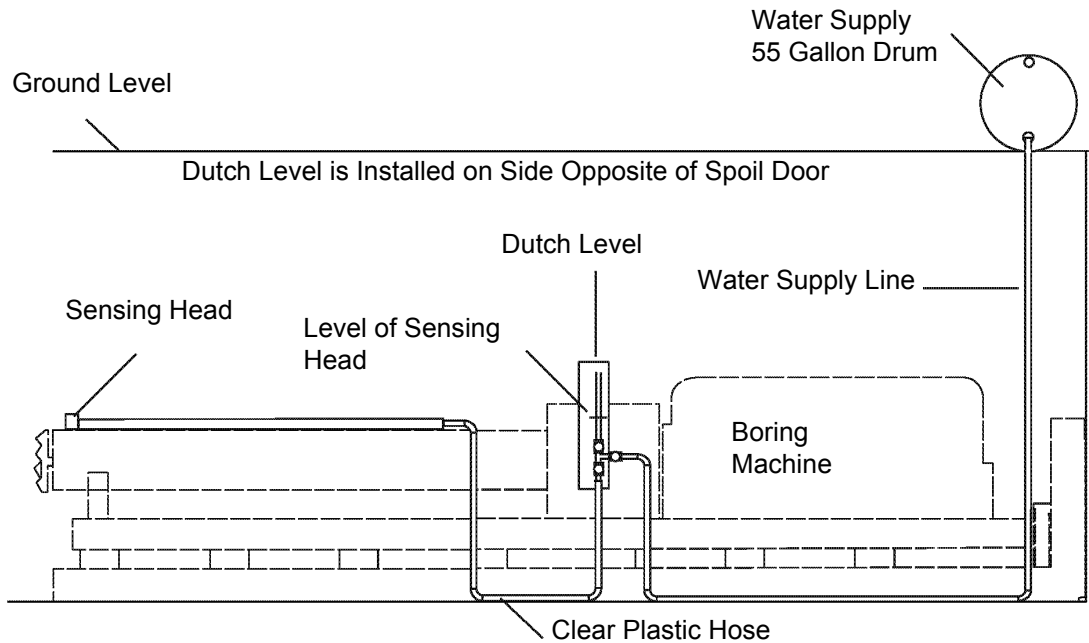

Figure 3: General layout of the Dutch Level Water Level.

### Securing the Water Line

Weld saddle clamps over 1/2 inch black water pipe to secure the pipe to the casing. The threaded pipe should end about one foot short of the back of the casing to allow hose connection ahead of the boring machine casing pusher. Mark the centerline at this point. This mark will be used to check for pipe rotation at the end of each push.

# Dutch Level Operators Manual

## Setup Procedure

### Locating the Pit Indicator

Secure a 2X6 or other reasonably flat piece of lumber to the wall of the pit at some convenient location, preferably where it would not be destroyed during the bore.

(We do not guarantee the instrument for failure due to crushing or banding.) Hang the indicator so the middle of the indicator sight tube is about at a level with the top of the casing pipe. Exact alignment of the indicator scale will be done during the filling and "topping off" operation.

### Connecting the System

Run a hose from the Inlet (top of indicator) to the water supply. If none is available, a 55 gallon drum at ground level will work, but keep it reasonably full. If it runs out during the bore, you will have to bleed the system to get the level working right again. Connect the 30 foot clear plastic hose from the pipe outlet (bottom right of indicator) to the water line on the casing. Keep this line off the track below the top of the casing, and long enough to reach when the push is finished.



### Setting up the System

The diagram below shows the valves of the Dutch Level Water Level.

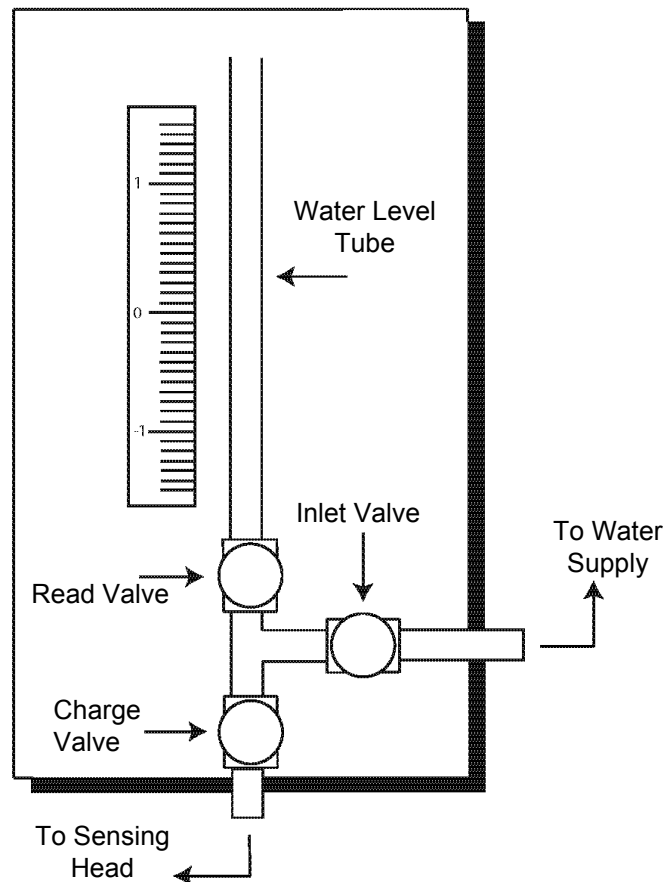

### Step 1

Turn on the water supply. Assure that water supply line to the Inlet Valve is full and free of bubbles

The diagram shows the valve settings.

### Bleed Water Supply Line and Charge System

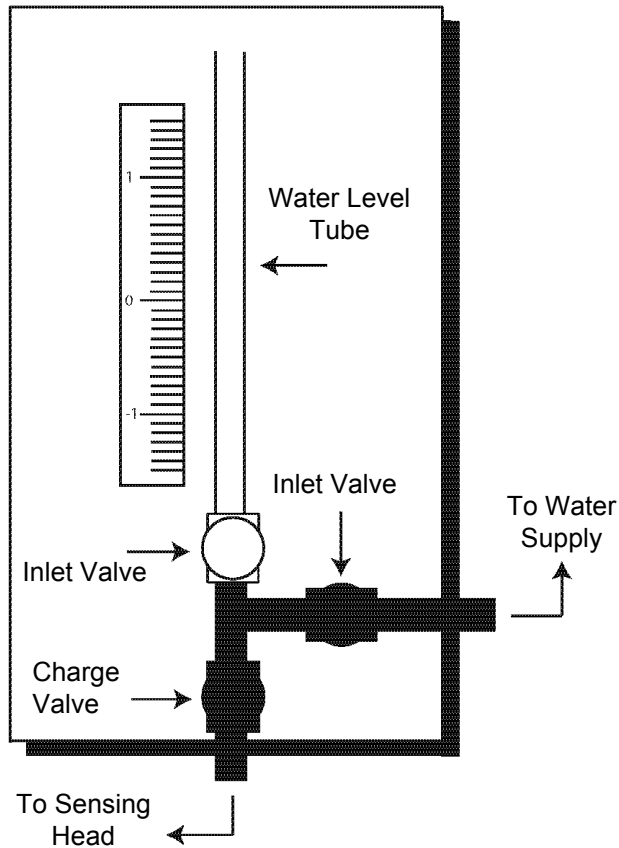

Let water run until all air comes out of sensing head, **DON'T** close Charge Valve

### Step 2

Charge system by opening the Inlet Valve and Charge Valve while read valve is closed. See the diagram above. Water will flow to and out of Sensing Head. Continue to charge until no bubbles are in clear plastic tube.

# Dutch Level Operators Manual

## Setup Procedure

---

### Step 3

Fill water level tube. Close Charge Valve and open Read Valve. Let water run until it fills Water Level Tube. Close Read Valve. See the diagram below.

#### Fill Water Level Tube

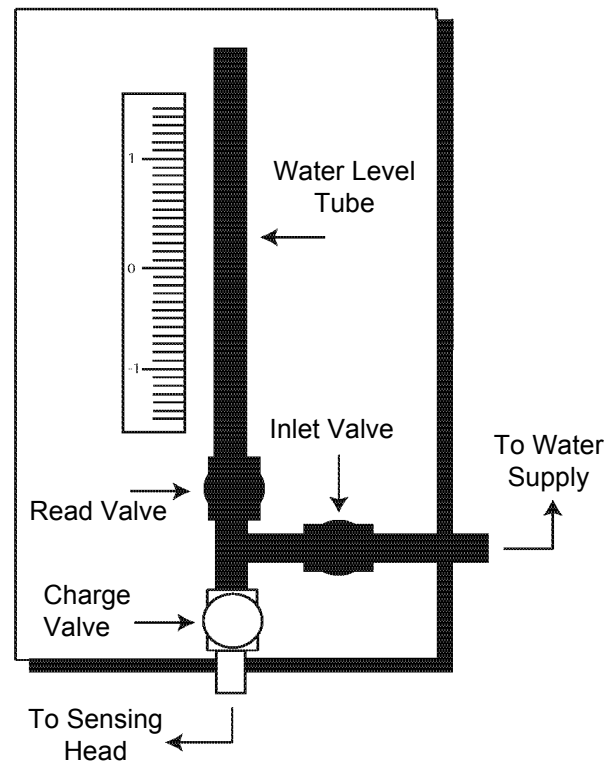

**Let water run until water in level tube reaches top, then close Read Valve.**

### Step 4 Read Level

Close Inlet Valve. Open Charge Valve. Slowly Open Read Valve and water will fall in gage to level of sensing head. See diagram below.

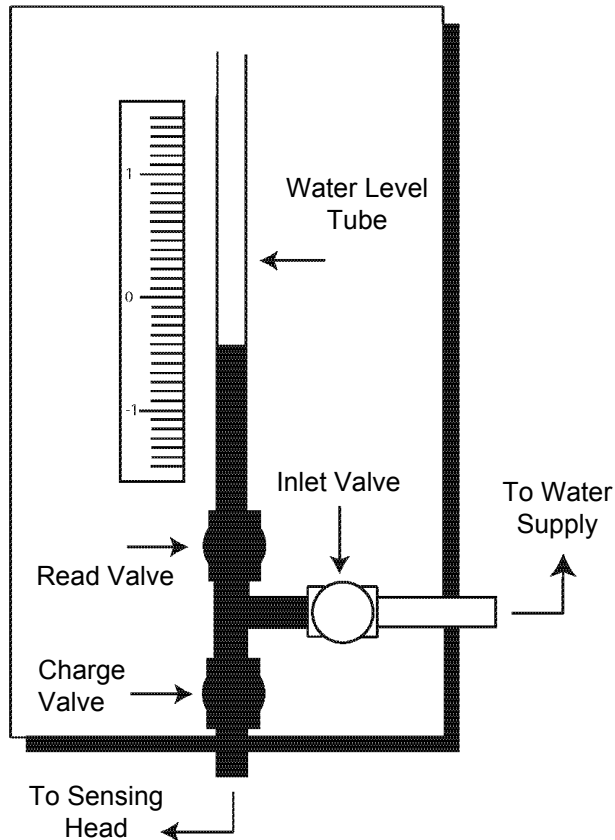

### Step 5 Adding New Pipe

As each push is completed, new casing and water pipe are added. Check the pipe center line mark for rotation. (If the pipe has rotated, grade readings will be in error by the amount of rotation.) When new pipe is added use pipe cement on all joints, and reconnect feed hose. (Remember to stop one foot in front of the casing pusher.) Repeat charging Steps 2 and 3. Do not adjust the indicator board.

### Step 6 Unplugging the Head Valve

If the water rises in the level tube and flows out the top, the "valve" is probably plugged. Try charging the system with "Read" Valve closed. Full water pressure should open the vent. Remember to open the Read Valve when you are done. If plugging conditions exist, you may want to bore with water running through the "valve" and obtain readings by "topping off."





American Augers, Inc.  
135 US Route 42  
P.O. Box 814  
West Salem, Ohio 44287  
[www.americanaugers.com](http://www.americanaugers.com)

Always include machine serial number when ordering parts  
Due to our continuing product improvement, machine specifications are subject to change without notice.

Manual Part Number BMDL40000  
Released August 2008 Revision 00